

# Manual BlueConnect Modules



with Supplement BlueConnect Plus Board

**Copyright**

According to the protective notes of DIN ISO 16016

"The reproduction, distribution and utilization of this document as well as the communication of its contents to others without express authorization are prohibited. Offenders will be held liable for the payment of damages. All rights reserved in the event of patent, utility model or design registration."

**Changes**

GO Systemelektronik GmbH retains the right to modify the contents of the manual without prior notice.

**Liability exclusion**

GO Systemelektronik GmbH takes no responsibility for correct system operation under all possible operating conditions. It is not possible to guarantee that the software will function completely without error under all possible circumstances. GO Systemelektronik GmbH therefore disclaims all liability for any direct or indirect damage resulting from system operation or the contents of this manual.

**Product observance**

Within the scope of our obligation for product observance GO Systemelektronik GmbH will endeavour to warn third parties about all identified dangers which could arise from the interaction between hardware and software and from the use of other components. Effective product observance is only possible with adequate information from the end user about the planned field of application and the hardware and software used. If the conditions of use change or if the hardware or software is changed, due to the complex relationships between hardware and software, it is no longer possible to describe all possible dangers and their effects on the total system, in particular on our system. This manual does not describe every possible property and combination of the system. For further information, please contact GO Systemelektronik GmbH.

**Manufacturer's declaration**

When installing the system, it is necessary to ensure correct electrical connection, protection against moisture and foreign bodies and excessive condensation, and system heating which can arise from both correct and incorrect use. It is the responsibility of the installer to ensure that the correct installation conditions are provided.

**Table of Contents**

1 Introduction .....4

2 Description of the BlueConnect Modules .....5

    2.1 System Setup Examples.....5

3 Technical Data and Connections.....6

    3.1 Opening the Module Housing.....6

    3.2 Cable Connections, Switch Positions and LEDs .....7

    3.3 PIN Assignment .....10

    3.4 PIN Assignment CAN Bus at the BlueBox.....10

4 Configuring the BlueConnect Modules with the Program Modbus Tool.exe .....11

    4.1 Preparation .....11

    4.2 Title Bar and Menu Bar .....12

    4.3 The Start Window (Modbus Connection) .....12

    4.4 The Info Window.....13

    4.5 The Calibration Window .....13

        4.5.1 The Calibration Table.....14

    4.6 The Measurement Value Window.....14

    4.7 The Measurement Value Recording Window .....15

    4.8 Configuring the Sensor Modules .....16

        4.8.1 The Parameter Window .....16

        4.8.2 The Calibration Window O2.....17

    4.9 Configuring the Current Input Module.....18

    4.10 Configuring the Current Output Module.....19

    4.11 Configuring the Relay Module.....20

    4.12 Configuring the Pulse Input Module .....21

    4.13 Configuring Older Bus Modules.....22

5 Modbus Addresses Overview of the Sensor Modules.....23

6 Modbus Addresses Overview Pulse Input 486 CI00-PI2 .....27

7 Supplement BlueConnect Plus Board .....28

Appendix A – Interior Cover Stickers.....29

Appendix B – Old Article Numbers .....31

Appendix C – EU Declaration of Conformity Sensor Module.....32

Appendix D – EU Declaration of Conformity I/O Module .....33

## 1 Introduction

This manual describes the BlueConnect Modules of GO Systemelektronik.

BlueConnect Modules are available in two basic variants, as Sensor Module and as Input-Output Module (I/O Module).

At the completion of this manual, the following types of design were available:

Sensor Modules	Article No.	Input-Output Modules	Article No.
Oxygen + Temp.	486 CS00-4	Current Input	486 CI00-AI2
pH + Temp.	486 CS00-5	Current Output	486 CI00-AO2
ISE + Temp.	486 CS00-7	RS232 Output Voltage 5 V	486 CI00-S05
ORP (Redox) + Temp.	486 CS00-9	RS232 Output Voltage 12 V	486 CI00-S12
Bus Module	486 CS00-MOD	Relay	486 CI00-REL
Bus Module Turb. flow through	486 CS00-FNU	Pulse Input	486 CI00-PI2



The type of version can be found on the sticker on the front of the housing ① or via the article number on the type plate on the right-hand side ② of the housing.

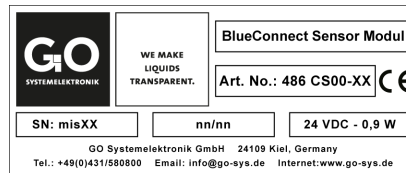

### ! Note on the article numbers

With the beginning of the year 2022, the BlueConnect Modules have been reassigned the article numbers listed above. The old article numbers are listed in Appendix B - Old Article Numbers.

### Note on Text References

References to passages in this document or to passages in other documents are marked in italics.

- *4.5 The Calibration Window* e.g. refers to the section 4.5 in this document. The short form is 4.5.

The products of GO Systemelektronik are constantly being developed, therefore deviations between this manual and the delivered product can result. Please understand that no legal claims can be derived from the contents of this manual.



**Caution:** The BlueConnect Modules must be installed in such a way that they are not exposed to direct sunlight, rain or snow. Direct sunlight can lead to extreme temperatures, which significantly reduces the service life of electronic components.

## 2 Description of the BlueConnect Modules

The BlueConnect Modules

- Transmit the measured values of analog sensors via CAN bus and Modbus.
- Transmit the measured values of Modbus sensors via CAN bus.
- Transmit the measured values of sensors to a PLC.
- Transmit the current values of analog current outputs via CAN bus and Modbus.
- Generate current values from measured values.
- Control an RS232 interface via CAN bus.
- Enable the control of relays with freely definable switching conditions.
- Generate measurement values from pulsed signals.

BlueConnect Modules are available in two basic variants, as Sensor Module and as Input-Output Module (I/O Module).

The necessary settings are made with a PC using the enclosed BlueConnect configuration program.

see 4 *Configuring the BlueConnect Modules with the Program Modbus Tool.exe*

The necessary settings of BlueConnect boards **without Modbus connection** are not made with the BlueConnect configuration program, but with the AMS program as part of the BlueBox PC Software (and partly also via the display control on the BlueBox).

### 2.1 System Setup Examples

Connection of analog sensors to a PLC system



Connection of analog sensors and Modbus sensors to a BlueBox System



Connection of analog sensors with additional power supply to a BlueBox System

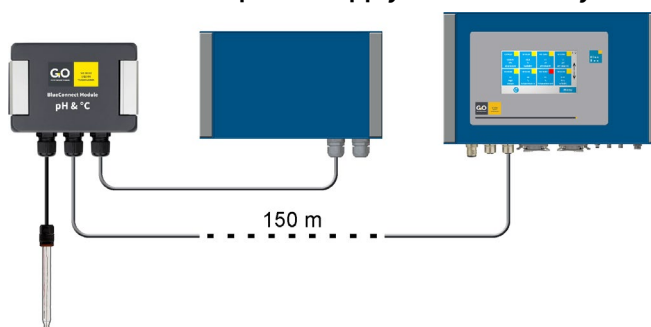

### 3 Technical Data and Connections

General Information	
Voltage supply	10 – 32 VDC
Power consumption	Sensor Modules: typical 0.9 W * Current Output Module: typical 0.9 W * RS232-Modul: typical 0.9 W * * plus Sensor consumption Current Output Module: typical 1.1 W plus load Relay Module: Pull-in power typical 2 x 0.17 W Pulse Input Module: typical 0.9 W
Dimensions (LxWxH)	124 x 115 x 63 mm
Weight	0.35 kg
IP protection code	IP66
Ambient temperature	-10 to +45 °C

Interfaces – depending on version	
CAN bus	Protocol is subset of CAN 2.0
Modbus	Modbus RTU via serial interface RS485
RS232	Serial interface RS232
Current input	Resistance 50 Ω 4 – 20 mA
Current Output	Resistance < 600 Ω 4 – 20 mA
Relay output	Umax 48 V Imax per Relais 2 A
Pulse Input	Frequency (rising edge) or static

- i Note Bus Module:** Modbus and CAN bus are galvanically isolated.
- i Note RS232 Modules:** RS232 and CAN bus are galvanically isolated.
- i Pulse Input Module:** The two pulse inputs are galvanically isolated from the system, but not from each other.

**⚡ Earth the module.**  
 This is the only way to ensure trouble-free measuring operation.  
 The earth connection is located on the left side of the housing.



#### 3.1 Opening the Module Housing

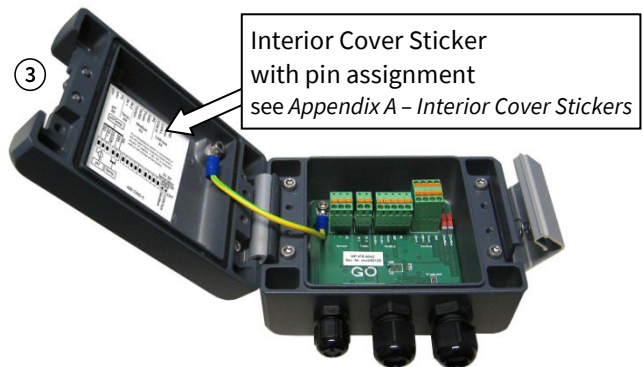

- ① Turn the housing bracket to the right. If necessary, use a suitable tool.
- ② Loosen the screws (Torx T20).
- ③ Open housing cover to the left.

### 3.2 Cable Connections, Switch Positions and LEDs

see also *Appendix A – Interior Cover Stickers*

- The module-specific assignment is shown on the sticker on the inside of the housing cover.
- The termination depends on the position of the module in the CAN bus/Modbus.  
see also next but one page *Notes on termination of older BlueConnect Modules*

 Earth the module. This is the only way to ensure trouble-free measuring operation.

#### Sensor Module O<sub>2</sub>, pH, ISE, ORP

The Modbus interface is optional.

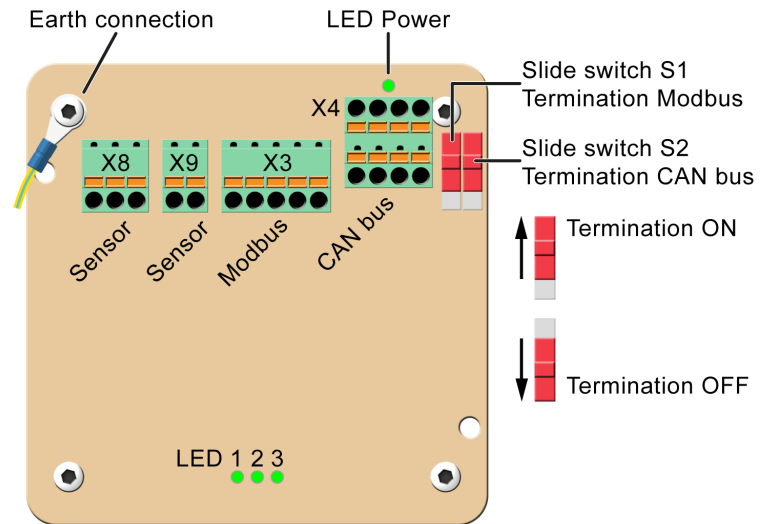

#### Bus Module

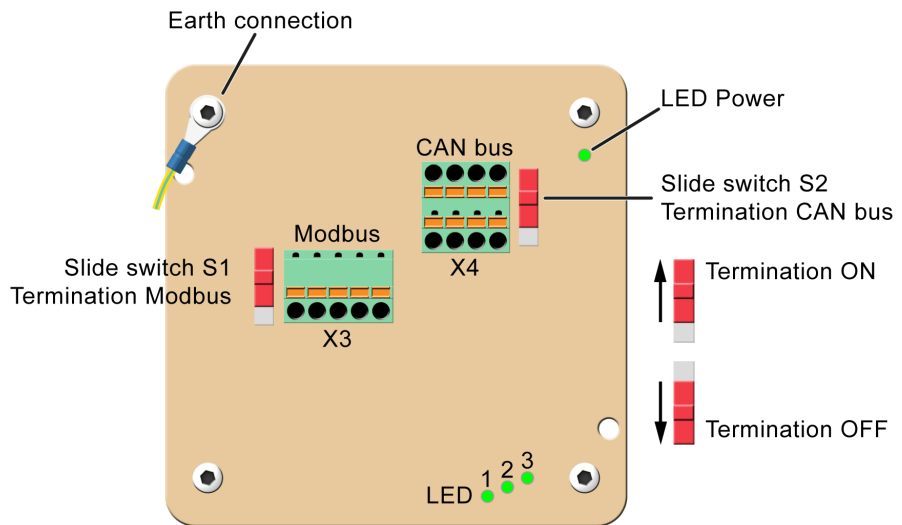

#### Current Input Module 2x 4 – 20 mA

The Modbus interface is optional.

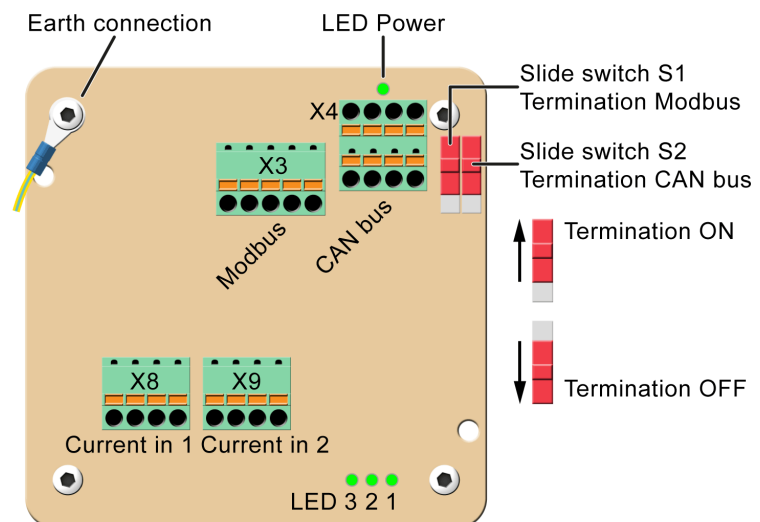

### Current Output Module 2x 4 – 20 mA

The Modbus interface is optional.

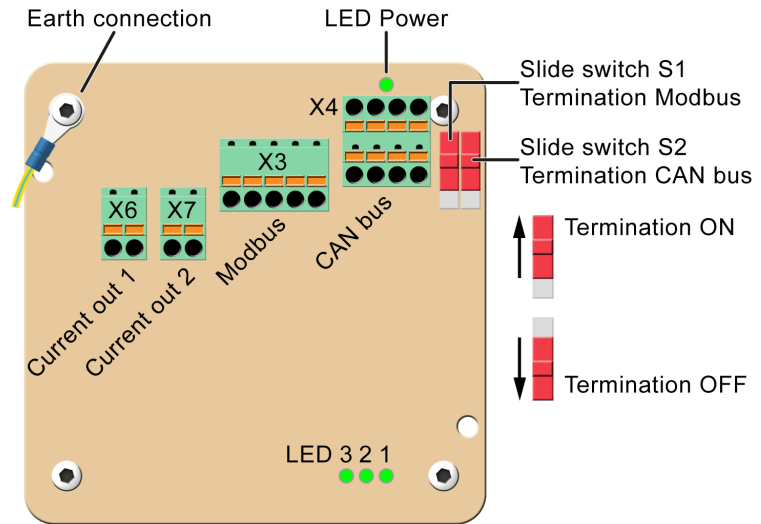

### RS232 Module

	OFF	ON	
A	↓	↓	COM1
B	↓	↓	COM2
C	↓	↓	COM3
D	↓	↓	COM4
	↑	↑	COM5
	↓	↓	COM6

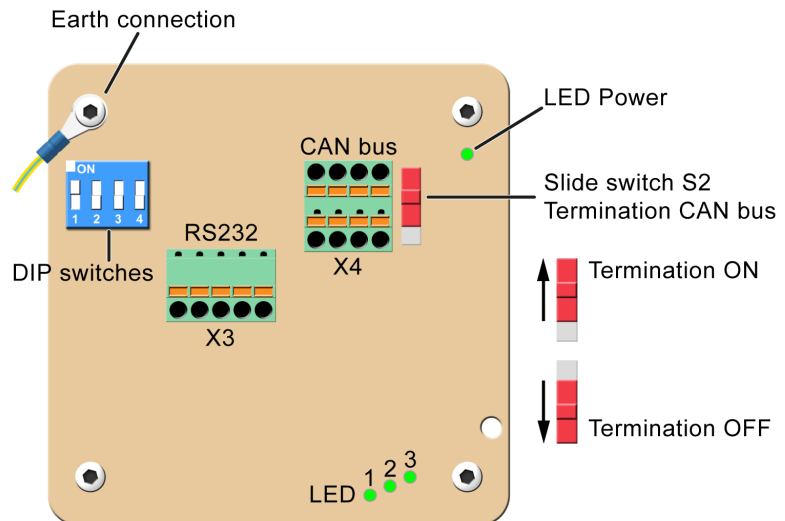

Setting the COM Port with the DIP switches  
Factory setting: COM2 (COM Port 2)

### Relay Module

The Modbus interface is optional.

Relay outputs  
U<sub>max</sub> = 48 V  
I<sub>max</sub> = 2 A per Relay

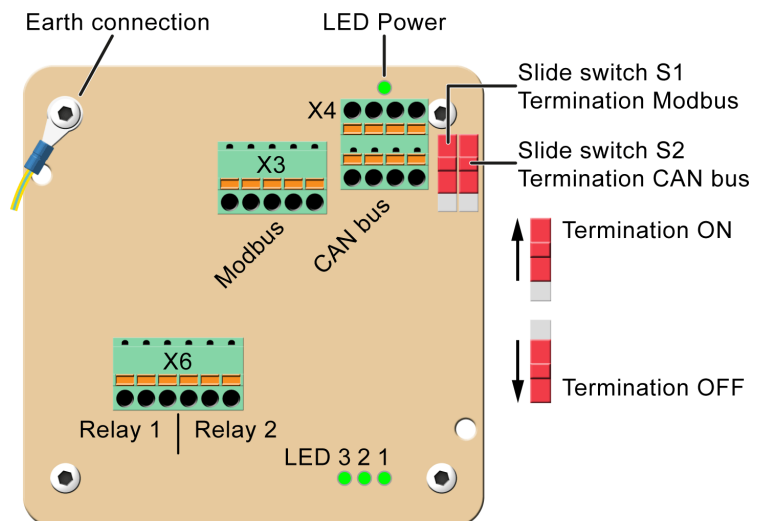



**Pulse Input Module**

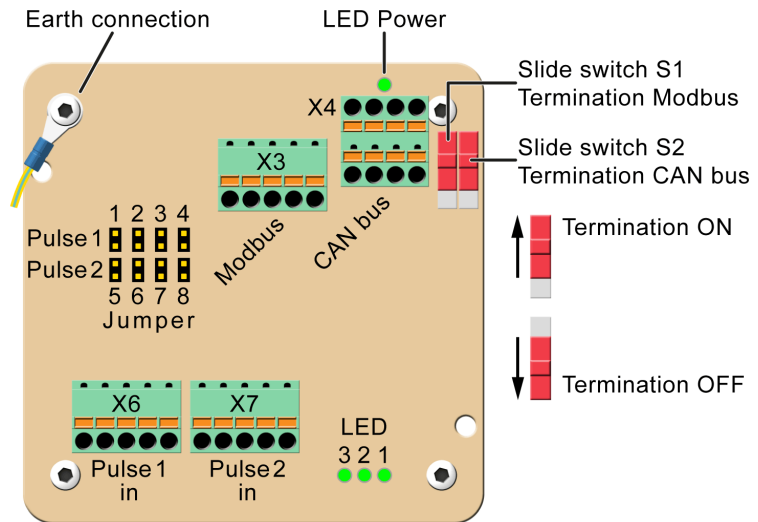
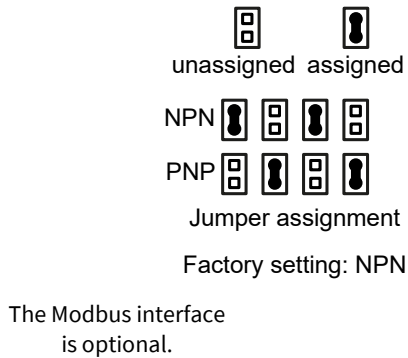

**LED-Functions**

- LED Power: Supply voltage is present
- LED 1: Flashing – frequency 0.5 Hz, main processor is in operation
- LED 2: Data transmission Modbus/RS232
- LED 3: Data transmission CAN bus

**Functionality of a cable clamp**

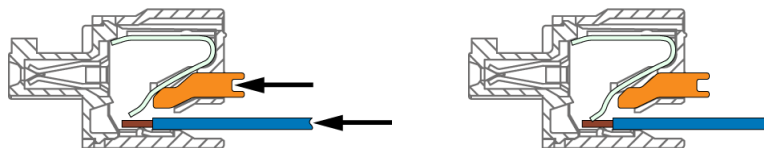

**Notes on termination of older BlueConnect Modules**

- Older modules have no slide switches on the board.

With older BlueConnect Sensor and Bus Modules, the termination of CAN bus and Modbus is done via the configuration program Modbus Tool.exe. see 4.7 Configuring Older Bus Modules

- Older modules are not terminated at the factory.

If there is no possibility to terminate the CAN bus via the configuration program: CAN bus termination by means of a resistor of approx. 120 Ω on the open terminals for CAN-H and CAN-L on slot X4. Modbus termination by means of a resistor of approx. 120 Ω on the open terminals for TX/RX+ and TX/RX- on slot X3.

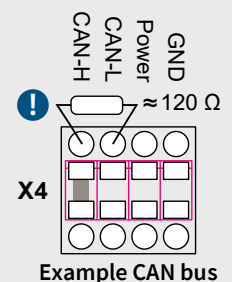

### 3.3 PIN Assignment

see also Appendix A – Interior Cover Stickers

**!** If the two terminals of slot X9 are not occupied, the open input must be terminated with a resistance of approx. 1.2 kΩ (except for O2/Temp, here approx. 27 kΩ).

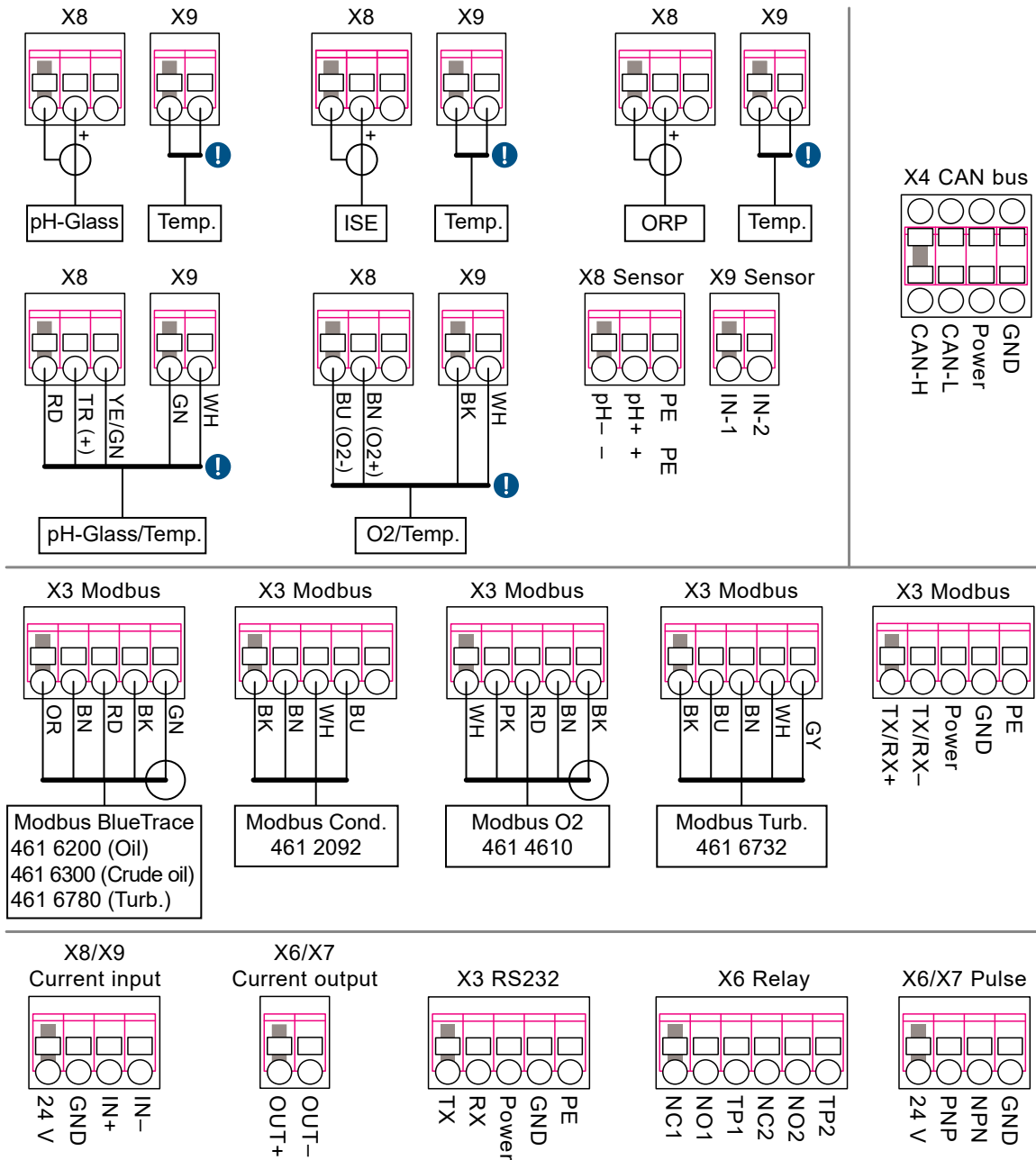

### 3.4 PIN Assignment CAN Bus at the BlueBox

#### BlueBox T4

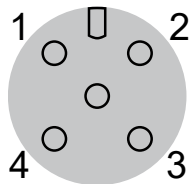

Panel socket (M12, female)

- 1** CAN-H
- 2** CAN-L
- 3** +24 VDC
- 4** GND 24 V



### Mainboard of the BlueBox R1 and BlueBox Panel

Slot X07 (BlueBox R1) or Slot X4 (BlueBox Panel)

- 1** CAN-H **2** CAN-L **3** +24 VDC **4** GND 24

see Manual BlueBox R1 and Panel

### 4 Configuring the BlueConnect Modules with the Program Modbus Tool.exe

This chapter describes the operation of the BlueConnect configuration program Modbus Tool.exe of GO Systemelektronik with the article number 420 6500 in **software version 1.10**. For example, you can use it (depending on the type of module and sensor) to read out sensor information, assign a Modbus address, calibrate the sensor and display measurement values.

On older Sensor and Bus Modules without slide switches, the Modbus (RS485) and the CAN bus can be terminated.<sup>1</sup>

- i** The **configuration of the Bus Module** is done automatically. The exception here are older bus modules, see *4.11 Configuring Older Bus Modules*.  
The **configuration of the Bus Module Turbidity flow through** is done at the BlueBox and is not described here.
- i** The calibration of the Sensor Modules can also be done via the menu operation on the BlueBox and with the BlueBox PC Software.
- i** The calibration of the Current Modules can also be done via the menu operation on the BlueBox and with the BlueBox PC Software.
- i** The **configuration of the RS232 Modules** is done via DIP switches.  
see *3.2 Cable Connections, Switch Positions and LEDs there RS232 Module*
- i** Decimal separator is the comma.

The program is executable under Windows 7 and newer. An Installation is not necessary, the program starts when Modbus Tool.exe is called up.

The program automatically detects the connected modules with their sensors.

Modbus Tool.exe is included with every BlueConnect Module.<sup>2</sup>

In the program windows, the internal designations of the modules are used:

- | pH + Temp. = BlueConnect pH | ISE + Temp. = BlueConnect ISE |  
| ORP + Temp. = BlueConnect Redox |
- | Oxygen = BlueConnect O2 | Conductivity = Conductivity | Oil in Water = BlueTrace Oil in Water |  
| Turbidity = BlueTrace Turbidity |
- | Current Input Module = BlueConnect Current In | Current Output Module = BlueConnect Current Out |  
| Relay Module = BlueConnect Relay | Pulse Input Module = BlueConnect Pulse Input |

#### 4.1 Preparation

In order for your PC to communicate with a Modbus sensor, you need a **converter from RS485 to USB** and **driver software**.

As an example, here is the Modbus USB<sup>3</sup> converter of GO Systemelektronik (Article No. 486 S810) with the driver software at: <https://ftdichip.com/drivers/d2xx-drivers> there „D2XX Drivers“  
The driver software creates a virtual COM Port in the Windows system – e.g. "USB Serial Port (COMn)".

Converter Slot X1  
connected with  
BlueConnect Module Slot X3

In case of communication problems:

- Check the earthing of the converter.
- Install the latest driver software.

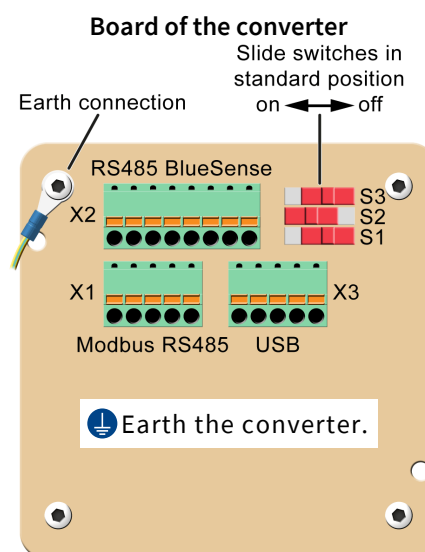

**Opening the converter housing: see 3.1 Opening the Module Housing**

<sup>1</sup> see also *3.2 Cable Connections, Switch Positions and LEDs there Notes on termination of older BlueConnect Modules*

<sup>2</sup> If not, contact GO Systemelektronik.

<sup>3</sup> USB 2.0 and newer

## 4.2 Title Bar and Menu Bar



① minimises the window - ② ③ closes the program - ④ selects the program language

## 4.3 The Start Window (Modbus Connection)

The Modbus connection window opens. Click on button <Start> ①.

The Select Port window ② opens with a selection option for the COM Ports existing on your computer. Here you must select the correct COM Port for communication with the converter.

The COM Port of the converter is displayed in the Windows Device Manager: **USB Serial Port (COMn)**

The program detects the connected BlueConnect Module.

Via ③ <Change COM Port> you can change the COM Port.

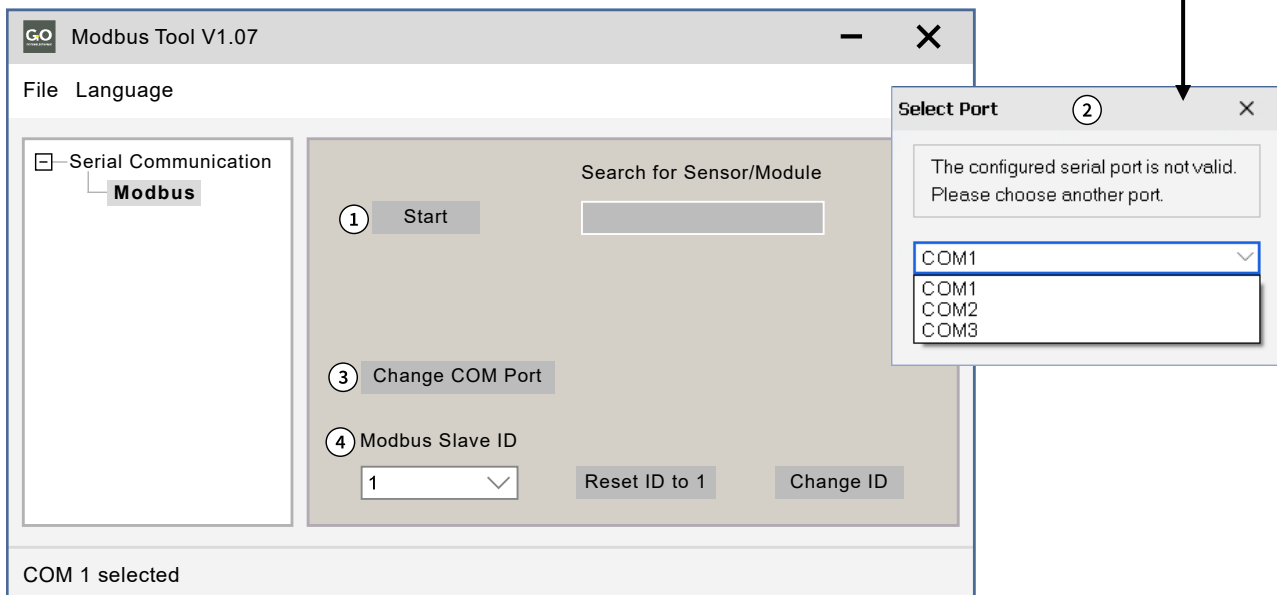

④ The default Modbus Slave ID of a BlueConnect Sensor Module is 1 and does not need to be changed.\*

\* In special cases contact GO Systemelektronik.

## 4.4 The Info Window

After the program has detected the connected module (here Redox/ORP), the module info window opens.

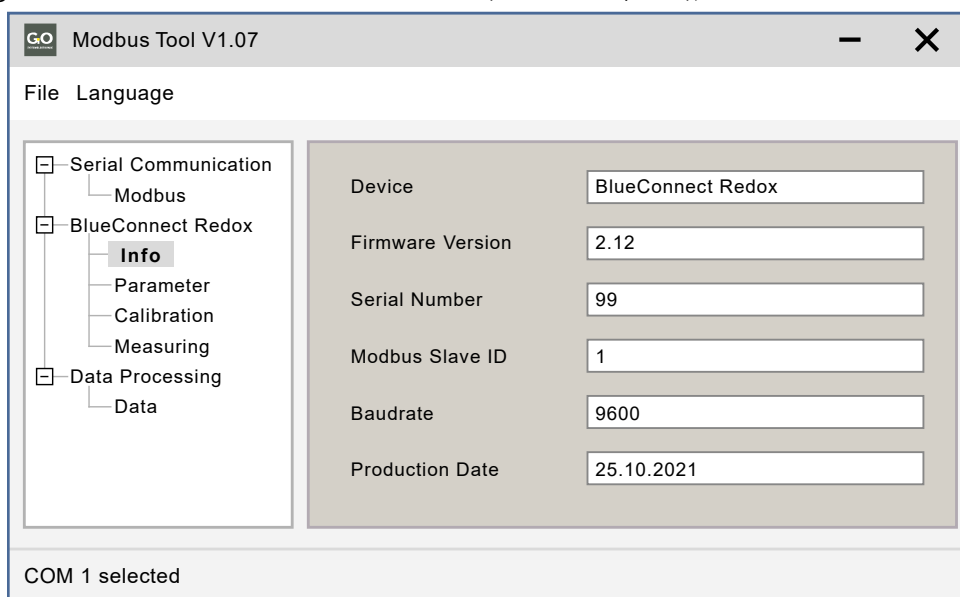

## 4.5 The Calibration Window

A calibration compares the **value pairs** of the measured **sensor raw values\*** and allocated **reference values** from calibration liquids. These value pairs are taken as points in a coordinate system. The curve of a 1. to 5. Order polynomial is placed through these points as accurately as possible, this is how the calibration polynomial is created.

**Example with a 2. Order polynomial:**

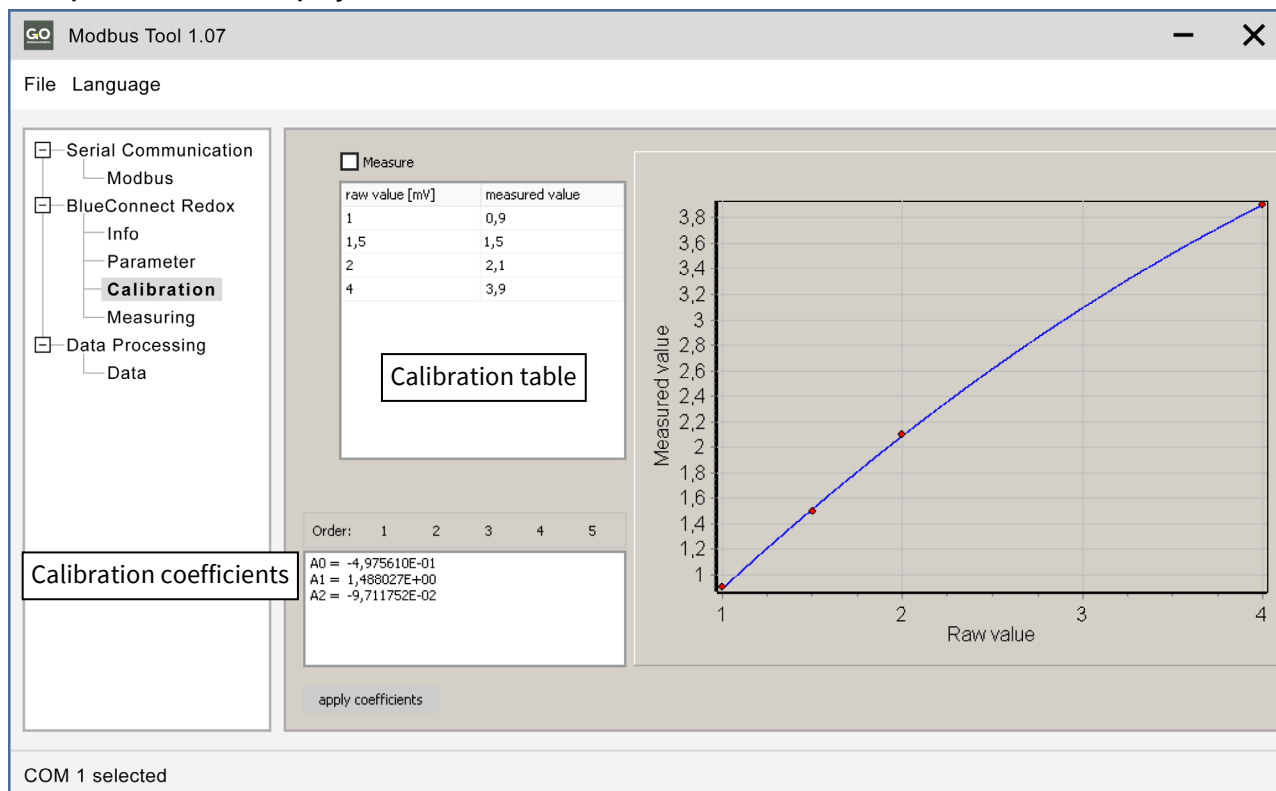

\* A raw sensor value is the uncalibrated sensor measurement value or the uncalibrated current input value.

## 4.5.1 The Calibration Table

There are two ways to enter the raw values:

- **manual input** – gives the possibility to calculate hypothetical calibrations
- **measurement value transfer** – current measured raw values for the actual calibration

The reference values are always entered manually. You can set up to 10 value pairs.



„**measured value [ppm]**“ is the reference value from a calibration liquid.

**Note:** Decimal separator is the comma; dots are not accepted.

**Manual input:** not activated:  **Measure**

After opening the calibration view the calibration table has only one row. Click the cursor into the “raw value” cell and enter the first raw value, click the cursor into the “measured value” cell and enter the first reference value, or vice versa.

**Measurement value transfer:** activated:  **Measure**

After first opening the calibration view the calibration table has only one row. Click the cursor on the first row pushbutton : As long as the row pushbutton is active  the current measurement raw value appears in the “raw value” cell. Click the cursor into the “measured value cell” and enter the first reference value.

To **create a new row**, click the cursor into the last row with an entry and press the ENTER-key.

To **delete a row**, delete all row entries and click in another row.

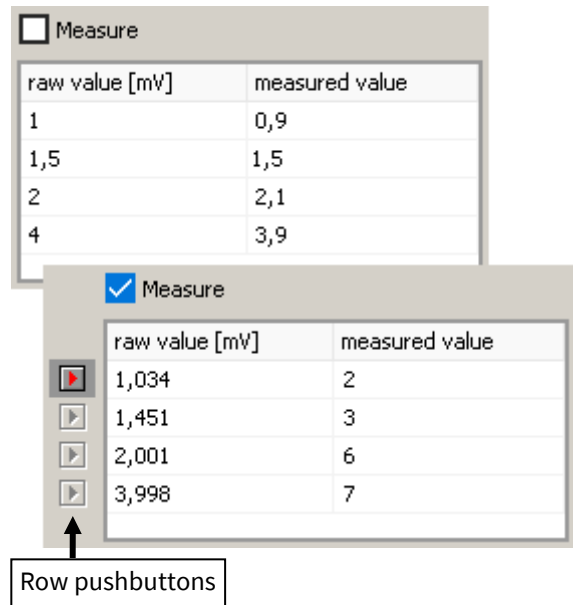

Row pushbuttons



**Order:** Order means the order/degree of the calibration polynomial. Click on one of the Order buttons 1 to 5 to get the best fit.



The graph of the calibration polynomial is displayed.

**apply coefficients** Writes the calculated coefficient values into the sensor.

## 4.6 The Measurement Value Window

   
Starts and stops the measurement value display.

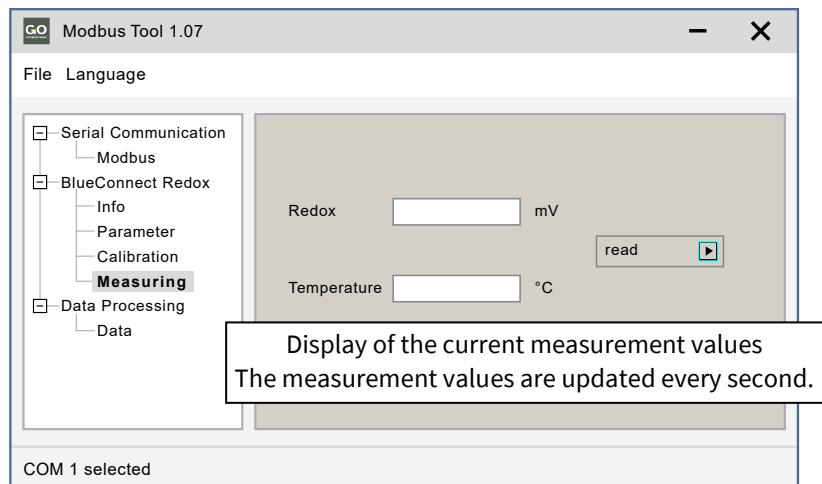

## 4.7 The Measurement Value Recording Window

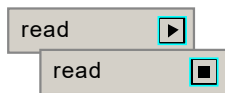
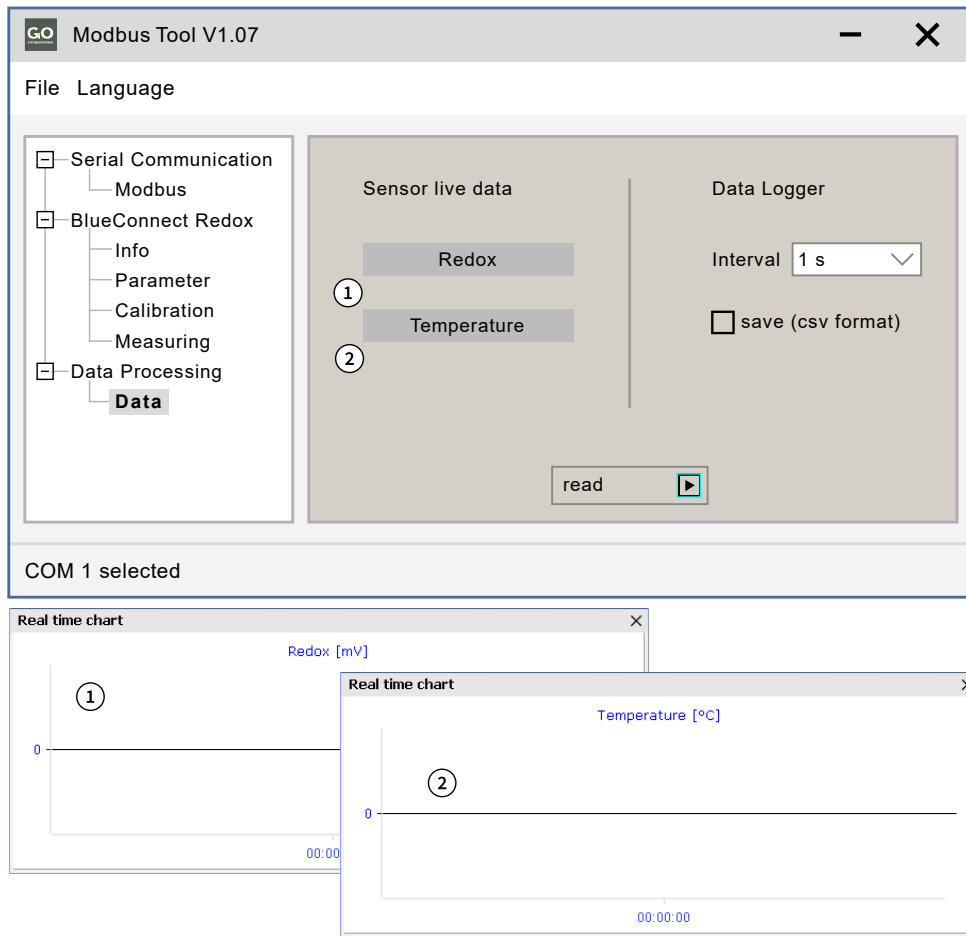

Starts and stops the running measurement value display.

**Interval** 1 s

Drop-down field for input/selection of the recording interval

save (csv format)

Opens a window for entering the storage path of a csv file. After the file has been created, the recording of the measurement values into the csv file starts.

The button changes to:

save (csv format)

At the bottom right of the program window this appears:



Click on <Stop> stops the data recording.

## 4.8 Configuring the Sensor Modules

### 4.8.1 The Parameter Window

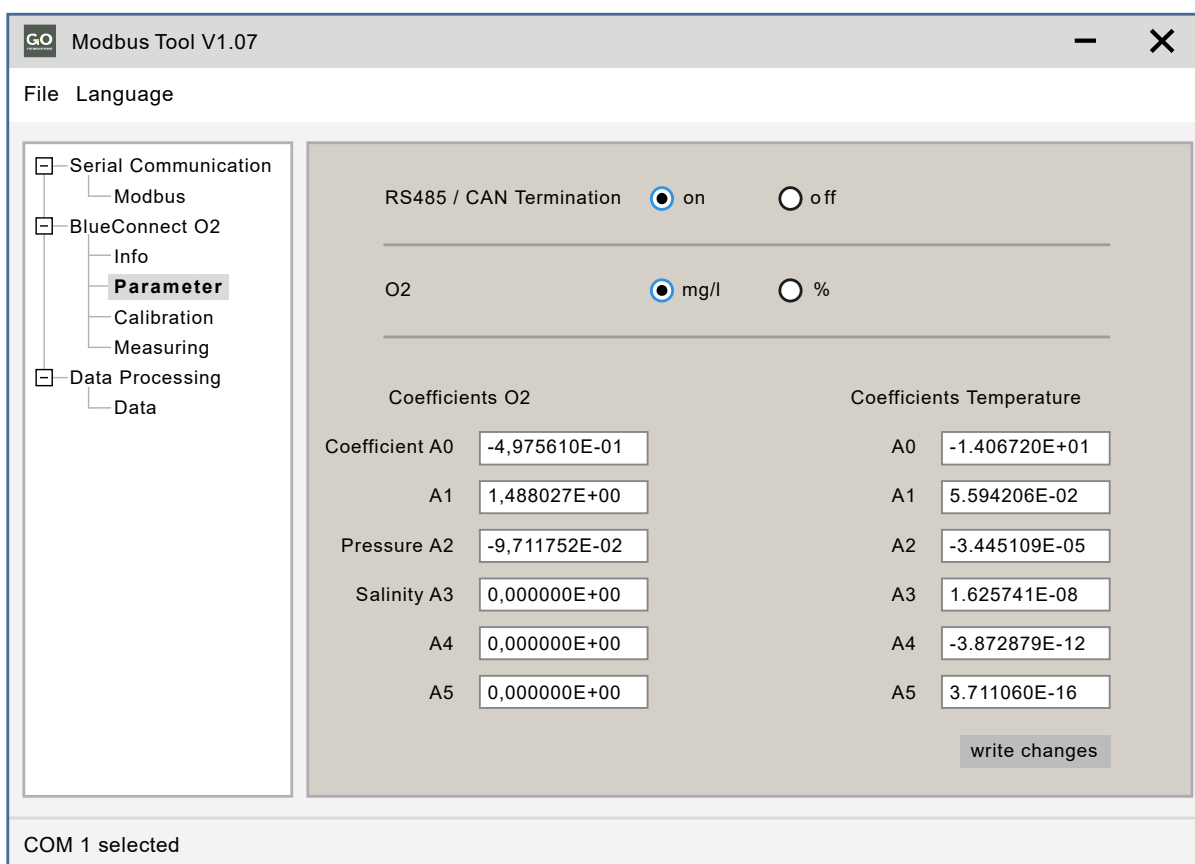

**RS485 / CAN Termination** Switches the termination of the Modbus (RS485) and the CAN bus on/off.

! Applies only to older BlueConnect Modules, the newer ones are terminated with slide switches on the board, see 3.2 *Cable Connections, Switch Positions and LEDs* there also *Note on termination of older BlueConnect Modules*. Newer modules with slide switches ignore the setting.

**O2** Only visible with O2 Sensor Modules.

Selection **mg/l** or **% Saturation**

This selection determines the type of calibration (see 4.8.2 *The Calibration Window O2*) and how the measurement value is stored and displayed

**Coefficients O2** Calibration coefficients, the displayed values are from the Calibration function, see 4.4 *The Calibration Window*.

**Coefficients Temperature** Only visible with Sensor Modules.

Factory calibration coefficients of an assigned temperature sensor\*. If necessary, you can determine the offset here via the Coefficient A0.



Writes the input settings into the module memory.  
**Settings that have not yet been saved are marked in red.**

**Note:** Decimal separator is the comma; if a dot is entered, an error message appears.

\* In this case, the internal temperature sensor of the O2 Sensor.



## 4.8.2 The Calibration Window O2

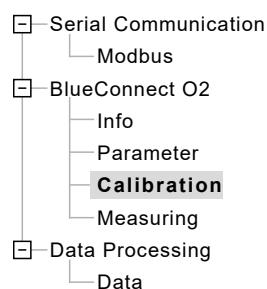

The calibration of the O2 sensor is a two-point calibration (calibration degree 0 polynomial). One point is the zero point, the other is determined by the **saturation in air** (100 %) or a pair of measured values from the measurement value of the sensor and the measurement value of a **reference measurement device** in the same measurement medium.

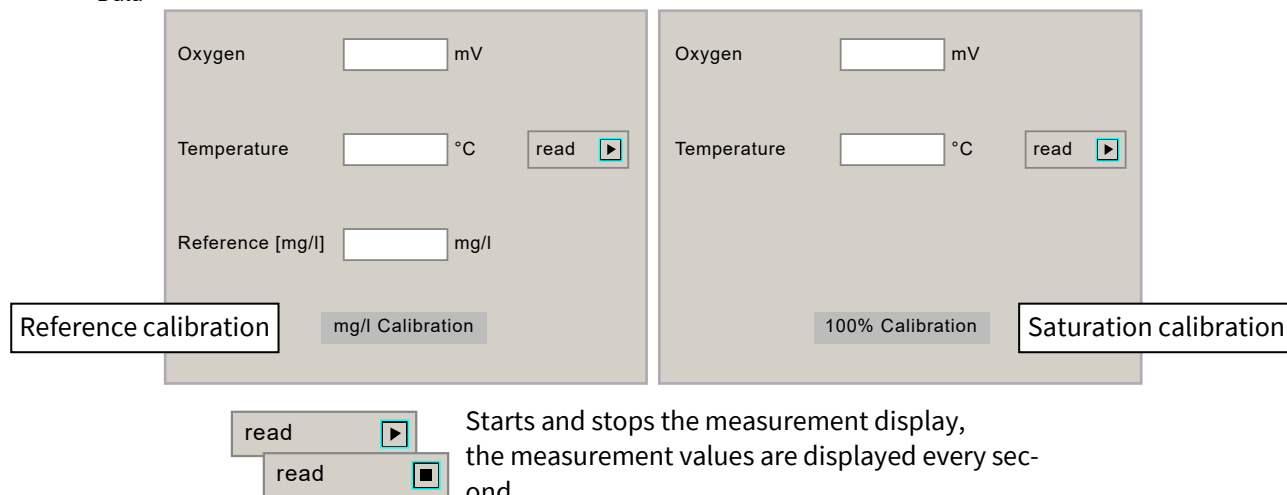

### Reference calibration

Prerequisite: Setting **O2 Unit**  mg/l

see 4.8.1 The Parameter Window

1. Click on <Start>
2. Immerse the oxygen sensor in your measurement medium and wait, until the displayed values are stable.
3. Entering<sup>1</sup> the oxygen content of the measurement medium according to the reference measuring device
4. Click on <mg/l Calibration>.
5. The calibration is completed.

### Saturation calibration

Prerequisite: Setting **O2 Unit**  %

see 4.8.1 The Parameter Window

1. Click on <Start>.
2. Hold the oxygen sensor in the air.<sup>2</sup>  
Wait at least 10 minutes until the displayed values are stable.
3. Click on <100% Calibration>.
4. The calibration is completed.

**Note:** Decimal separator is the comma; if a dot is entered, an error message appears.

<sup>1</sup> Decimal separator is the comma; if a full stop is entered, an error message appears.

<sup>2</sup> The galvanic cell for oxygen measurement is located at the bottom of the sensor body, the temperature sensor is near the center. Therefore, a saturation calibration in the air can only be carried out when the entire sensor body has reached the temperature of the ambient air. The larger the difference in temperature between the measuring medium and the ambient air, the greater the time required for a temperature adjustment (30 minutes or more, if applicable).  
The temperature adjustment can be accelerated by immersing the sensor in water, which has approximately the temperature of the ambient air, before performing the saturation calibration.  
Moreover, abrupt temperature changes (e.g., by direct exposure to the sun) must be avoided.

## 4.9 Configuring the Current Input Module

The Current Input Module has two current inputs with 4 – 20 mA. For calibration of the current inputs see 4.5 and 4.5.1.

Parameter window of the Current Input Module

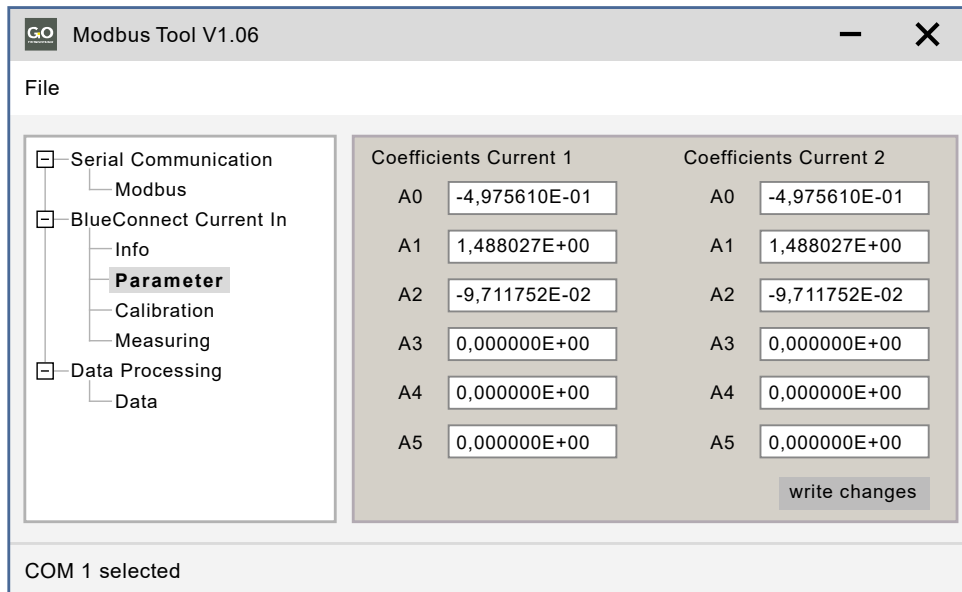

**Coefficients Current 1** Calibration coefficients, the displayed values are from the  
**Coefficients Current 2** Calibration function, see 4.4 *The Calibration Window*.

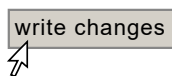

Writes the input settings into the module memory.  
**Settings that have not yet been saved are marked in red.**

**Note:** Decimal separator is the comma; if a dot is entered, an error message appears.

## 4.10 Configuring the Current Output Module

The Current Output Module has two current outputs with 4 – 20 mA. For calibration of the current outputs see 4.5 and 4.5.1.

Parameter window of the Current Output Module

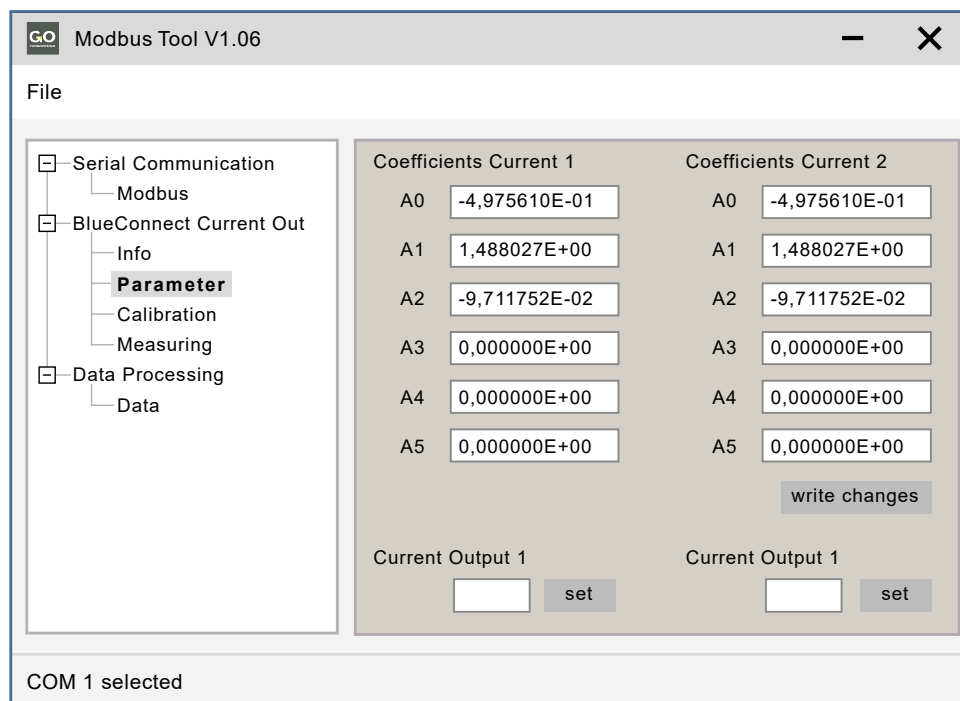

**Coefficients Current 1**  
**Coefficients Current 2**

Calibration coefficients, the displayed values are from the Calibration function, see 4.5 *The Calibration Window*.

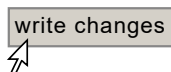

Writes the input settings into the module memory.  
**Settings that have not yet been saved are marked in red.**

**Current Output 1**  
**Current Output 1**

For test purposes, you can enter input values here.

By clicking on  the module outputs the corresponding current value.

Resetting to the operating state is done by disconnecting the module from the supply voltage.

**Note:** Decimal separator is the comma; if a dot is entered, an error message appears.

## 4.11 Configuring the Relay Module

The Relay Module has two relays.

Parameter window of the Relay Module

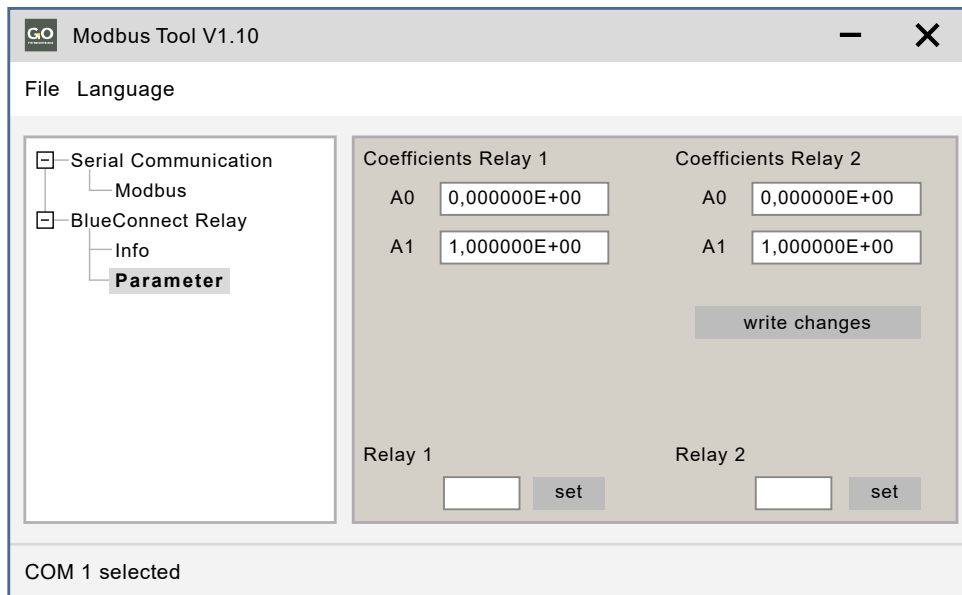

### Coefficients Relay 1 Coefficients Relay 2

You can change the switching value via these coefficients ( $y = A0 + A1x$ ).<sup>\*</sup> Factory setting:  $A0 = 0$   $A1 = 1$

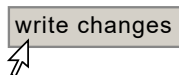

Writes the input settings into the module memory.  
**Settings that have not yet been saved are marked in red.**

### Relay 1 Relay 2

For test purposes, you can enter input values here (usually 0 and 1). These input values correspond to the values transmitted by the BlueBox<sup>\*</sup>.

Click on  switches the relay or not.



Resetting to the operating state is done by disconnecting the module from the supply voltage.

**i Note:** Decimal separator is the comma; if a dot is entered, an error message appears.

<sup>\*</sup> The BlueBox transmits values to the relay module. If these values are not changed by the above-mentioned coefficients (i.e.  $A0 \neq 0$  and/or  $A1 \neq 1$ ), a relay switches at transmitted values of  $\geq 0.5$ . Normally, the transmitted values are limited to 0 and 1 with the BlueBox PC Software and are set with the BlueConnect factory settings (see above).

## 4.12 Configuring the Pulse Input Module

The Pulse Input Module has two pulse inputs.

Parameter window of the Pulse Input Module (in factory setting)

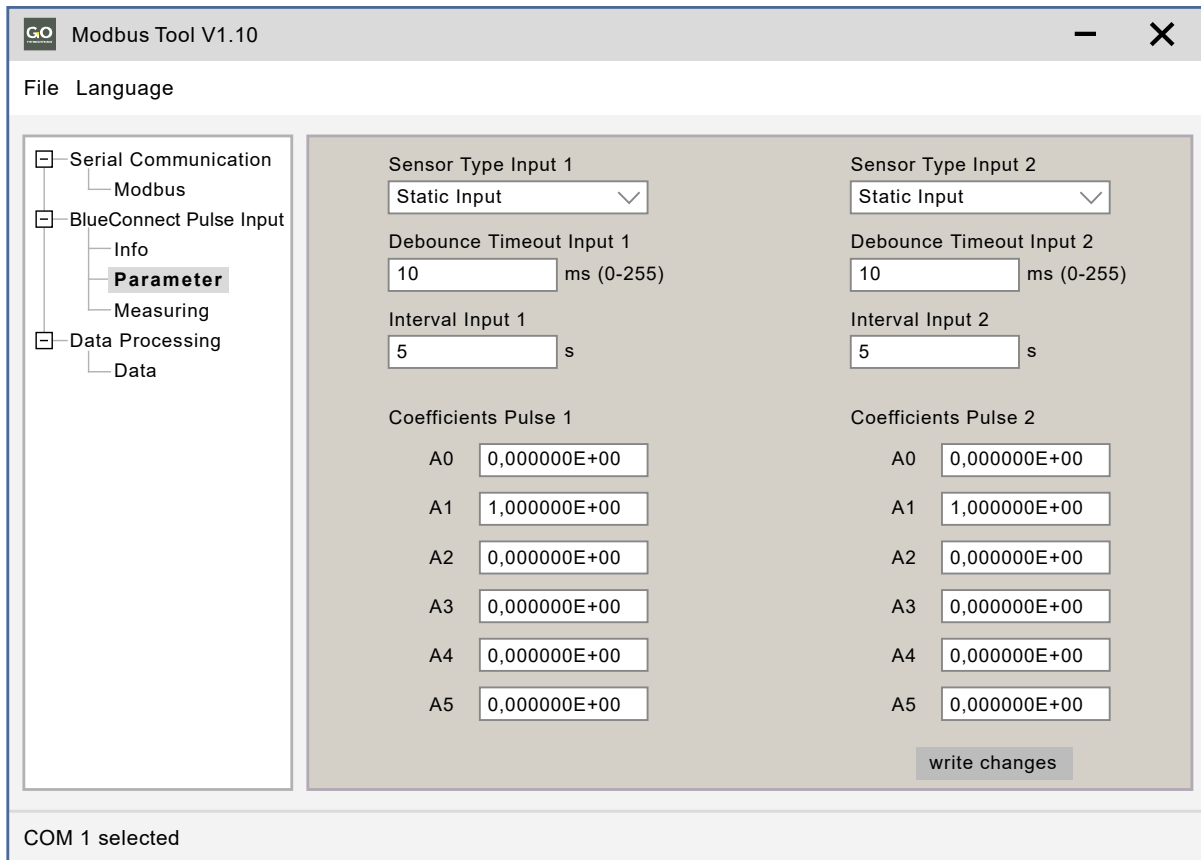

- Sensor Type Input 1** Clicking on  opens a drop-down menu for selecting the input type:
- Sensor Type Input 2**
- Static input
  - Frequency (edge trigger) – Triggering on the rising edge.
  - Frequency (debounced) – Triggering on the rising edge with debounce dead time as entered.
  - Watchdog (only CAN) – If there is no pulse in the entered measuring interval, a measurement value of 0 is output at the CAN bus interface, otherwise 1.

**Debounce Timeout input 1** Entering the timeout after triggering in ms [0 – 255]  
**Debounce Timeout input 2**

**Interval Input 1** Entering the Measurement Interval in s  
**Interval Input 2** In the factory setting of the coefficients (see picture above), the measurement value is the number of pulses in the measurement interval.

**Coefficients Pulse 1** Entering the coefficients  
**Coefficients Pulse 2** Is used to adapt to the pulse generator and to convert the measured value of the measurement value (e.g. Hz to l/min).

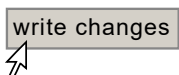

Writes the input settings into the module memory.  
**Settings that have not yet been saved are marked in red.**

 **Note:** Decimal separator is the comma; if a dot is entered, an error message appears.

## 4.13 Configuring Older Bus Modules

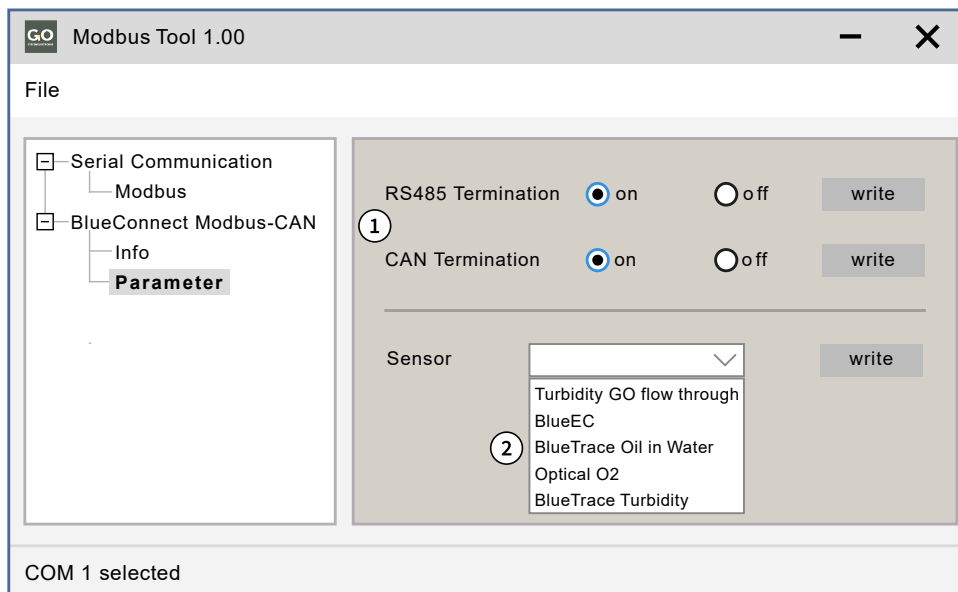

- ① Older BlueConnect Bus Modules do not have slide switches on the board. Here, the termination is done via the Parameter Window.

**RS485 Termination** Selection Modbus (RS485) termination selection on/off

**CAN Termination** Selection CAN bus termination on/off

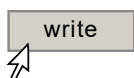

Writes the selected termination into the module memory.  
**Settings that have not yet been saved are marked in red.**

- ! Only applies to older BlueConnect Bus Modules, the newer ones are terminated with slide switches on the board, see *3.2 Cable Connections, Switch Positions and LEDs* there also *Notes on termination of older BlueConnect Modules*.  
Newer modules with slide switches ignore the setting.

- ② With older BlueConnect Bus Modules, connected Modbus sensors are not automatically detected. The appropriate sensor identifier must be selected via the drop-down menu.

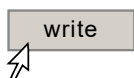

Writes the selected sensor identifier into the module memory.  
**Settings that have not yet been saved are marked in red.**

**5 Modbus Addresses Overview of the Sensor Modules**
**BlueConnect O2 486 CS00-4 - Modbus Addresses Overview**

31.8.2021

Address	Parameter name	Range	Meaning	Data type	Authorisation
0x00	Device ID	104	104 - BlueConnect O2	Short	R
0x01	Firmware Version	100 - 9999	100 = 1.00, 2410 = 24.1	Short	R
0x02	Serial No.	0 - 65535	Serial number	Short	R
0x03	Modbus Slave ID	1 - 230	Modbus Address	Short	R/W
0x04	Baud rate	0 - 2	0 = 9600 8N1	Short	R
0x05	Production date	ddmmyyyy	Date	Short x 2	R

Address	Parameter name	Range	Meaning	Data type	Authorisation
0x14	A0	0 - 0xffffffff	Cal Coefficient	32 Bit Float	R/W
0x16	A1	0 - 0xffffffff		32 Bit Float	R/W
0x18	A2	0 - 0xffffffff	Air Pressure	32 Bit Float	R/W
0x1A	A3	0 - 0xffffffff	Salinity	32 Bit Float	R/W
0x1C	A4	0 - 0xffffffff		32 Bit Float	R/W
0x1E	A5	0 - 0xffffffff		32 Bit Float	R/W

Address	Parameter name	Range	Meaning	Data type	Authorisation
0xD0	Measuring Unit	0 - 1	0: mg/l 1: %	Short	R/W

Address	Parameter name	Range	Data type	Authorisation
0x101	O2 [mg/l or %]	0 - 0xffffffff	32 Bit Float	R
0x104	Temperature [°C]	0 - 0xffffffff	32 Bit Float	R

**Note on 32 bit Float data** (MSB = 0xByte4, LSB = 0xByte1),  
 The Receiving sequence of the values (Hex) is: 0x [Byte2] [Byte1] [Byte4] [Byte3]

Address	Parameter name	Range	Meaning	Data type	Authorisation
0x00	Device ID	103	103 - BlueConnect pH	Short	R
0x01	Firmware Version	100 - 9999	100 = 1.00, 2410 = 24.1	Short	R
0x02	Serial No.	0 - 65535	Serial number	Short	R
0x03	Modbus Slave ID	1 - 230	Modbus Address	Short	R/W
0x04	Baud rate	0 - 2	0 = 9600 8N1	Short	R
0x05	Production date	ddmmyyyy	Date	Short x 2	R

Address	Parameter name	Range	Meaning	Data type	Authorisation
0x14	A0	0 - 0xffffffff	Cal Coefficient A0	32 Bit Float	R/W
0x16	A1	0 - 0xffffffff	Cal Coefficient A1	32 Bit Float	R/W
0x18	A2	0 - 0xffffffff	Cal Coefficient A2	32 Bit Float	R/W
0x1A	A3	0 - 0xffffffff	Cal Coefficient A3	32 Bit Float	R/W
0x1C	A4	0 - 0xffffffff	Cal Coefficient A4	32 Bit Float	R/W
0x1E	A5	0 - 0xffffffff	Cal Coefficient A5	32 Bit Float	R/W

Address	Parameter name	Range	Data type	Authorisation
0x101	pH	0 - 0xffffffff	32 Bit Float	R
0x104	Temperature [°C]	0 - 0xffffffff	32 Bit Float	R

**Note on 32 bit Float data** (MSB = 0xByte4, LSB = 0xByte1),  
 The Receiving sequence of the values (Hex) is: 0x [Byte2] [Byte1] [Byte4] [Byte3]



Address	Parameter name	Range	Meaning	Data type	Authorisation
0x00	Device ID	105	103 - BlueConnect ISE	Short	R
0x01	Firmware Version	100 - 9999	100 = 1.00, 2410 = 24.1	Short	R
0x02	Serial No.	0 - 65535	Serial number	Short	R
0x03	Modbus Slave ID	1 - 230	Modbus Address	Short	R/W
0x04	Baud rate	0 - 2	0 = 9600 8N1	Short	R
0x05	Production date	ddmmyyyy	Date	Short x 2	R

Address	Parameter name	Range	Meaning	Data type	Authorisation
0x14	A0	0 - 0xffffffff	Cal Coefficient A0	32 Bit Float	R/W
0x16	A1	0 - 0xffffffff	Cal Coefficient A1	32 Bit Float	R/W
0x18	A2	0 - 0xffffffff	Cal Coefficient A2	32 Bit Float	R/W
0x1A	A3	0 - 0xffffffff	Cal Coefficient A3	32 Bit Float	R/W
0x1C	A4	0 - 0xffffffff	Cal Coefficient A4	32 Bit Float	R/W
0x1E	A5	0 - 0xffffffff	Cal Coefficient A5	32 Bit Float	R/W

Address	Parameter name	Range	Data type	Authorisation
0x101	ISE [mg/l]	0 - 0xffffffff	32 Bit Float	R
0x104	Temperature [°C]	0 - 0xffffffff	32 Bit Float	R

**Note on 32 bit Float data** (MSB = 0xByte4, LSB = 0xByte1),  
 The Receiving sequence of the values (Hex) is: 0x [Byte2] [Byte1] [Byte4] [Byte3]

Address	Parameter name	Range	Meaning	Data type	Authorisation
0x00	Device ID	106	106 – BlueConnect Redox	Short	R
0x01	Firmware Version	100 – 9999	100 = 1.00, 2410 = 24.1	Short	R
0x02	Serial No.	0 – 65535	Serial number	Short	R
0x03	Modbus Slave ID	1 – 230	Modbus Address	Short	R/W
0x04	Baud rate	0 – 2	0 = 9600 8N1	Short	R
0x05	Production date	ddmmyyyy	Date	Short x 2	R

Address	Parameter name	Range	Meaning	Data type	Authorisation
0x14	A0	0 – 0xffffffff	Cal Coefficient A0	32 Bit Float	R/W
0x16	A1	0 – 0xffffffff	Cal Coefficient A1	32 Bit Float	R/W
0x18	A2	0 – 0xffffffff	Cal Coefficient A2	32 Bit Float	R/W
0x1A	A3	0 – 0xffffffff	Cal Coefficient A3	32 Bit Float	R/W
0x1C	A4	0 – 0xffffffff	Cal Coefficient A4	32 Bit Float	R/W
0x1E	A5	0 – 0xffffffff	Cal Coefficient A5	32 Bit Float	R/W

Address	Parameter name	Range	Data type	Authorisation
0x101	Redox [mV]	0 – 0xffffffff	32 Bit Float	R
0x104	Temperature [°C]	0 – 0xffffffff	32 Bit Float	R

**Note on 32 bit Float data** (MSB = 0xByte4, LSB = 0xByte1),  
 The Receiving sequence of the values (Hex) is: 0x [Byte2] [Byte1] [Byte4] [Byte3]

**6 Modbus Addresses Overview Pulse Input 486 CI00-PI2**

10.5.2022

Address	Parameter name	Range	Meaning	Data type	Authorisation
0x00	Device ID	112	112 – BlueConnect Pulse Input	Short	R
0x01	Firmware Version	100 – 9999	100 = 1.00, 2410 = 24.1	Short	R
0x02	Serial No.	0 – 65535	Serial Number	Short	R
0x03	Modbus Slave ID	1 – 230	Modbus Address	Short	R/W
0x04	Baud rate	0 – 2	0 = 9600 8N1	Short	R
0x05	Production date	ddmmyyyy	Date	Short x 2	R

**Pulse Input 1**

Address	Parameter name	Range	Meaning	Data type	Authorisation
0x14	A0	0 – 0xffffffff	Cal Coefficient A0	32 Bit Float	R/W
0x16	A1	0 – 0xffffffff	Cal Coefficient A1	32 Bit Float	R/W
0x18	A2	0 – 0xffffffff	Cal Coefficient A2	32 Bit Float	R/W
0x1A	A3	0 – 0xffffffff	Cal Coefficient A3	32 Bit Float	R/W
0x1C	A4	0 – 0xffffffff	Cal Coefficient A4	32 Bit Float	R/W
0x1E	A5	0 – 0xffffffff	Cal Coefficient A5	32 Bit Float	R/W

**Pulse Input 2**

Address	Parameter name	Range	Meaning	Data type	Authorisation
0x24	A0	0 – 0xffffffff	Cal Coefficient A0	32 Bit Float	R/W
0x26	A1	0 – 0xffffffff	Cal Coefficient A1	32 Bit Float	R/W
0x28	A2	0 – 0xffffffff	Cal Coefficient A2	32 Bit Float	R/W
0x2A	A3	0 – 0xffffffff	Cal Coefficient A3	32 Bit Float	R/W
0x2C	A4	0 – 0xffffffff	Cal Coefficient A4	32 Bit Float	R/W
0x2E	A5	0 – 0xffffffff	Cal Coefficient A5	32 Bit Float	R/W

Address	Parameter name	Range	Data type	Authorisation
0x101	Messwert Puls Input 1	0 – 0xffffffff	32 Bit Float	R
0x104	Messwert Puls Input 2	0 – 0xffffffff	32 Bit Float	R

**Note on 32 bit Float data** (MSB = 0xByte4, LSB = 0xByte1),  
 The Receiving sequence of the values (Hex) is: 0x [Byte2] [Byte1] [Byte4] [Byte3]

## BlueConnect - Supplement BlueConnect Plus Board

### 7 Supplement BlueConnect Plus Board

The BlueConnect Plus board can be equipped with up to four BlueConnect boards. The BlueConnect Plus board can be installed internally in a BlueBox as well as in a sensor module.

The connection is made via the CAN bus connection. The individual BlueConnect boards appear as DAM (Data Acquisition Module) in the BlueBox System.

The necessary settings of BlueConnect boards **without Modbus connection** are not made with the BlueConnect configuration program, but with the AMS program as part of the BlueBox PC Software (and partly also via the display control on the BlueBox).

A BlueConnect board is mounted with 4 hex socket screws (⌀ 3 mm) each.

The board slots 1 to 4 can be equipped with BlueConnect boards as desired. In this example, slot 1 is equipped with a bus board and slot 2 with an RS232 board.

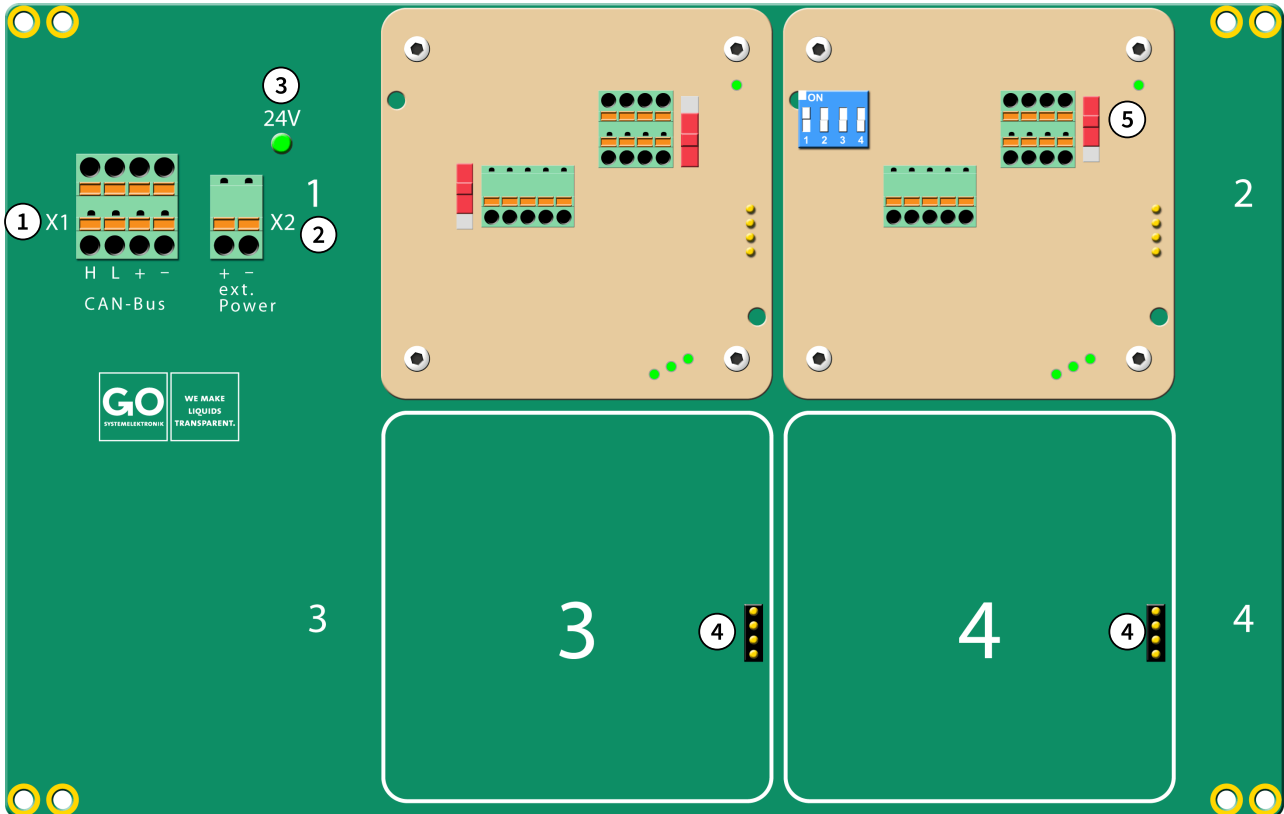

- ① The connection to the BlueBox System is made via the CAN bus connection X1.
- ② An additional voltage supply can be connected via connection X2.
- ③ The LED lights up when the BlueConnect Plus board is supplied with voltage.
- ④ The CAN bus connection of the BlueConnect boards is made via the pin headers at slots 1 to 4.



- ⑤ The CAN bus termination of the BlueConnect Plus board is done with the slide switch to the right of the CAN bus connection of the last BlueConnect board in the sequence (here on slot 2).

Slide switch S2 – Termination CAN bus

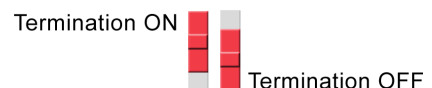

#### Terminal assignment:

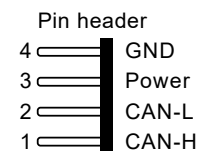
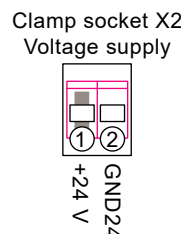
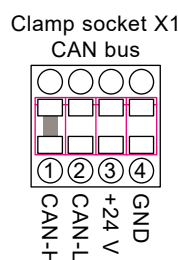

## Appendix A - Interior Cover Stickers

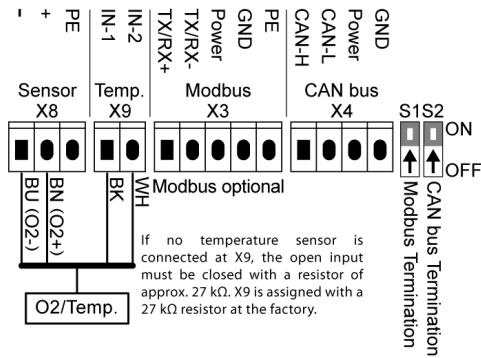

486 CS00-4

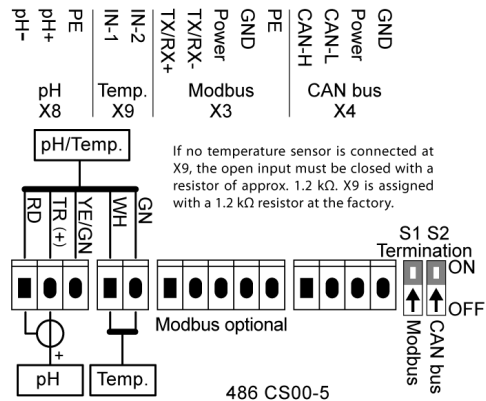

486 CS00-5

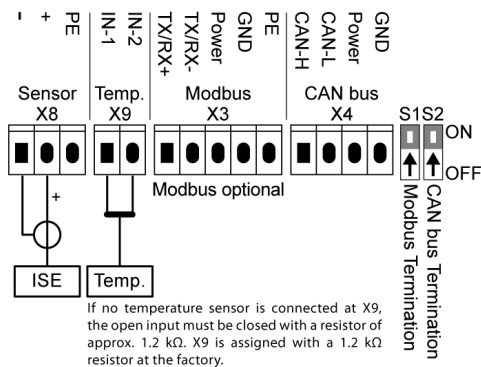

486 CS00-7

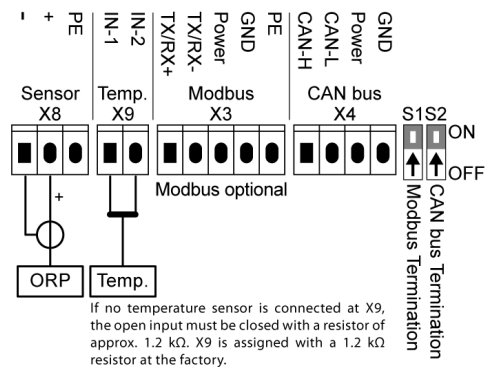

486 CS00-9

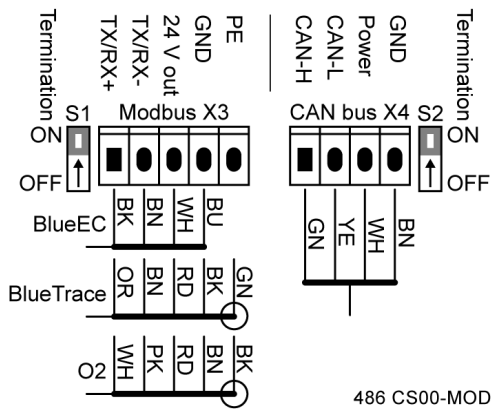

486 CS00-MOD

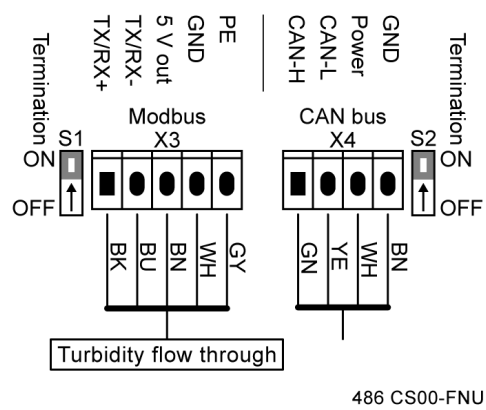

486 CS00-FNU

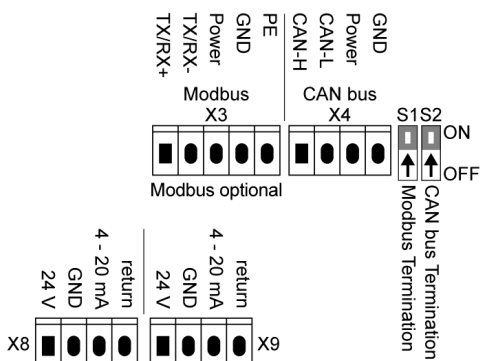

486 CI00-AI2

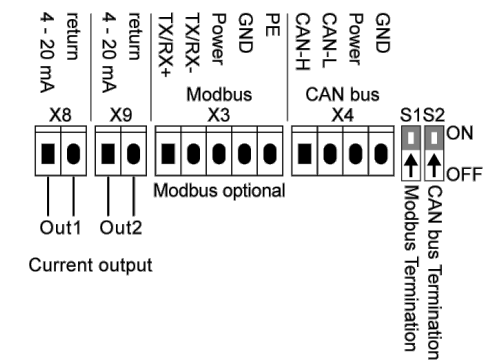

486 CI00-AO2

# BlueConnect - Interior Cover Stickers

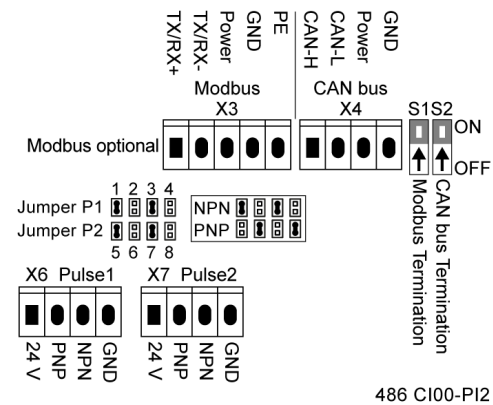
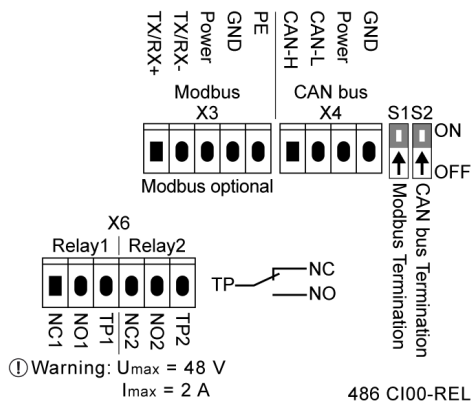
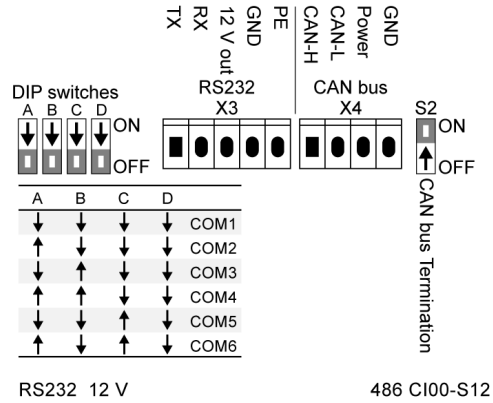
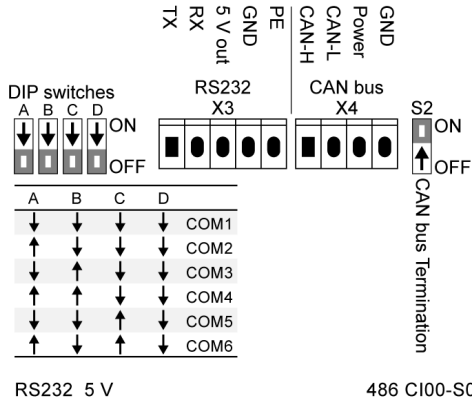

**Appendix B - Old Article Numbers**

Sensor Modules	Article No. old
Oxygen + Temp.	486 C000-4
pH + Temp.	486 C000-5
ISE + Temp.	486 C000-7
ORP (Redox) + Temp.	486 C000-9

Current Modules	Article No. old
Current Input	486 C000-mAI
Current Output	486 C000-mAO

Bus Module	Article No. old
	486 C000-MOD

Bus Module Turbidity	Article No. old
(Turbidity flow through)	486 C000-TURB

RS232 Modules	Article No. old
Output Voltage 5 V	486 C000-RS05
Output Voltage 12 V	486 C000-RS12

Relay Module	Article No. old
	486 C000-REL

Appendix C - EU Declaration of Conformity Sensor Module



**EU-Konformitätserklärung**  
**EU Declaration of Conformity**

**Hersteller:** GO Systemelektronik GmbH  
**Manufacturer:** Faluner Weg 1  
24109 Kiel Germany

Die alleinige Verantwortung für die Ausstellung dieser Konformitätserklärung trägt der Hersteller.  
*The sole responsibility for issuing this EU declaration of conformity is carried by the manufacturer.*

**Gegenstand dieser Erklärung:** BlueConnect Sensor Modul  
**Subject to this declaration:** BlueConnect Sensor Module

**Artikelnummer:** 486 CS00-XX  
**Article No.:**

**Typenschild des Produktes:**  
**Type plate of the product:**

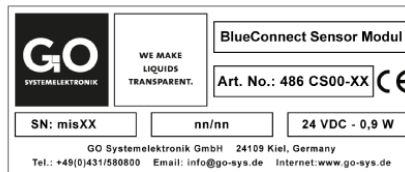

Der oben beschriebene Gegenstand der Erklärung erfüllt die einschlägigen Harmonisierungsvorschriften der Union.  
*The subject matter described above fulfills the relevant harmonization rules of the Union.*

**Zugrunde liegende harmonisierte Normen:**  
**Underlying harmonized standards:**

- 1. DIN EN 61000-6-3:2011 Störaussendung *Interference emission*
- 2. DIN EN 61000-6-1:2007 Störfestigkeit *Interference resistance*

(Falls zutreffend) **Gemäß den Bestimmungen der Richtlinie/den Dokumenten:**  
*(If applicable) Following the provision of directive/the documents:*

- 1. DIN EN 62368-1 Niederspannungsrichtlinie *Low voltage directive*
- 2. Fertigungs- und Prüfanweisung BlueConnect-Modul PA 486 CS00-XX  
*Manufacturing and test instruction BlueConnect Module*
- 3. Bedienungsanleitung BlueConnect-Module *Manual BlueConnect Modules*

Kiel, 11.1.2022  
Ort, Datum der Ausstellung  
*Place, date of issue*

  
-----  
Dr. Thorsten Knutz  
Geschäftsführer *Managing director*

GO Systemelektronik GmbH Faluner Weg 1 24109 Kiel Germany Tel.: +49 431 58080-0 Fax: -58080-11  
www.go-sys.de info@go-sys.de **Seite Page 1 / 1**



Appendix D - EU Declaration of Conformity I/O Module



**EU-Konformitätserklärung**  
**EU Declaration of Conformity**

**Hersteller:** GO Systemelektronik GmbH  
**Manufacturer:** Faluner Weg 1  
24109 Kiel Germany

Die alleinige Verantwortung für die Ausstellung dieser Konformitätserklärung trägt der Hersteller.  
*The sole responsibility for issuing this EU declaration of conformity is carried by the manufacturer.*

**Gegenstand dieser Erklärung:** BlueConnect I/O Modul  
**Subject to this declaration:** BlueConnect I/O Module

**Artikelnummer:** 486 CI00-XX  
**Article No.:**

**Typenschild des Produktes:**  
**Type plate of the product:**



Der oben beschriebene Gegenstand der Erklärung erfüllt die einschlägigen Harmonisierungsvorschriften der Union.  
*The subject matter described above fulfills the relevant harmonization rules of the Union.*

**Zugrunde liegende harmonisierte Normen:**  
**Underlying harmonized standards:**

1. DIN EN 61000-6-3:2011 Störaussendung *Interference emission*
2. DIN EN 61000-6-1:2007 Störfestigkeit *Interference resistance*

(Falls zutreffend) **Gemäß den Bestimmungen der Richtlinie/den Dokumenten:**  
*(If applicable) Following the provision of directive/the documents:*

1. DIN EN 62368-1 Niederspannungsrichtlinie *Low voltage directive*
2. Fertigungs- und Prüfanweisung BlueConnect-Modul PA 486 CI00-XX  
*Manufacturing and test instruction BlueConnect Module*
3. Bedienungsanleitung BlueConnect-Module *Manual BlueConnect Modules*

Kiel, 11.1.2022  
Ort, Datum der Ausstellung  
*Place, date of issue*

  
-----  
Dr. Thorsten Knutz  
Geschäftsführer *Managing director*

GO Systemelektronik GmbH Faluner Weg 1 24109 Kiel Germany Tel.: +49 431 58080-0 Fax: -58080-11  
www.go-sys.de info@go-sys.de **Seite Page 1 / 1**